

Acoustics Consultant:	NAGATA ACOUSTICS, Inc.
Architect:	Okada & Associates Architects Engineers Planners
Owners:	Toppan Printing Co. Ltd.
Sound & Communications:	NAGATA ACOUSTICS, Inc.
Construction Cost:	¥ 25,000 Million JPY (approx.)

Toppan Hall is a new concert hall constructed in commemoration of the hundredth anniversary of foundation of the Toppan Printing Co. Ltd in Tokyo in October 2000.

The hall was designed mainly as a chamber music and recital hall. It has a sloped floor with 408 seats in a rectangular space.

One of the problems in the planning stage was the sound isolation between the hall and the Printing Museum, located just under the hall. To solve the problem the entire hall was supported by floating structures.

In order to meet the requirements of various styles and sizes of concerts, as well as occasional ceremonies and lectures, variable absorption panels were mounted on both upper side walls. The reverberation time is changeable from 1.1 to 1.4 second with full audience. The wall around the stage and audience is made with wooden ribs in order to scatter sound reflections.

BUILDING DETAILS AND ACOUSTICS DATA

Location	1-3-3 Suido, bunkyo-ku, Tokyo 112-8531, Japan
Tel	03-5840-2211
Seating Capacity	408
Room Volume	3,700 CM
Surface Area	1,700 SM
Stage Area	95 SM
Reverberation Time (Mid-Frequency)	
Unoccupied	1.3 sec - 1.6 sec
Occupied	1.1 sec - 1.4 sec
Finishing Materials	
Ceiling	: Glassfibre reinforced cement panel, 3 layers of gypsum board (8 mm x 3)
Lower Wall	: Wooden lattice work + 3 layers of wooden surfaced gypsum board (8 mm x 3)
Upper Wall	: Variable absorption panel
Floor	: 33 mm wooden board on concrete
Seat	: Upholstered
Miscellaneous	: Variable absorption panel
Noise Level	: NC-15
Total Cost	: ¥ 25,000 Million JPY (approx.)
Total Floor Area	: 54,219 SM

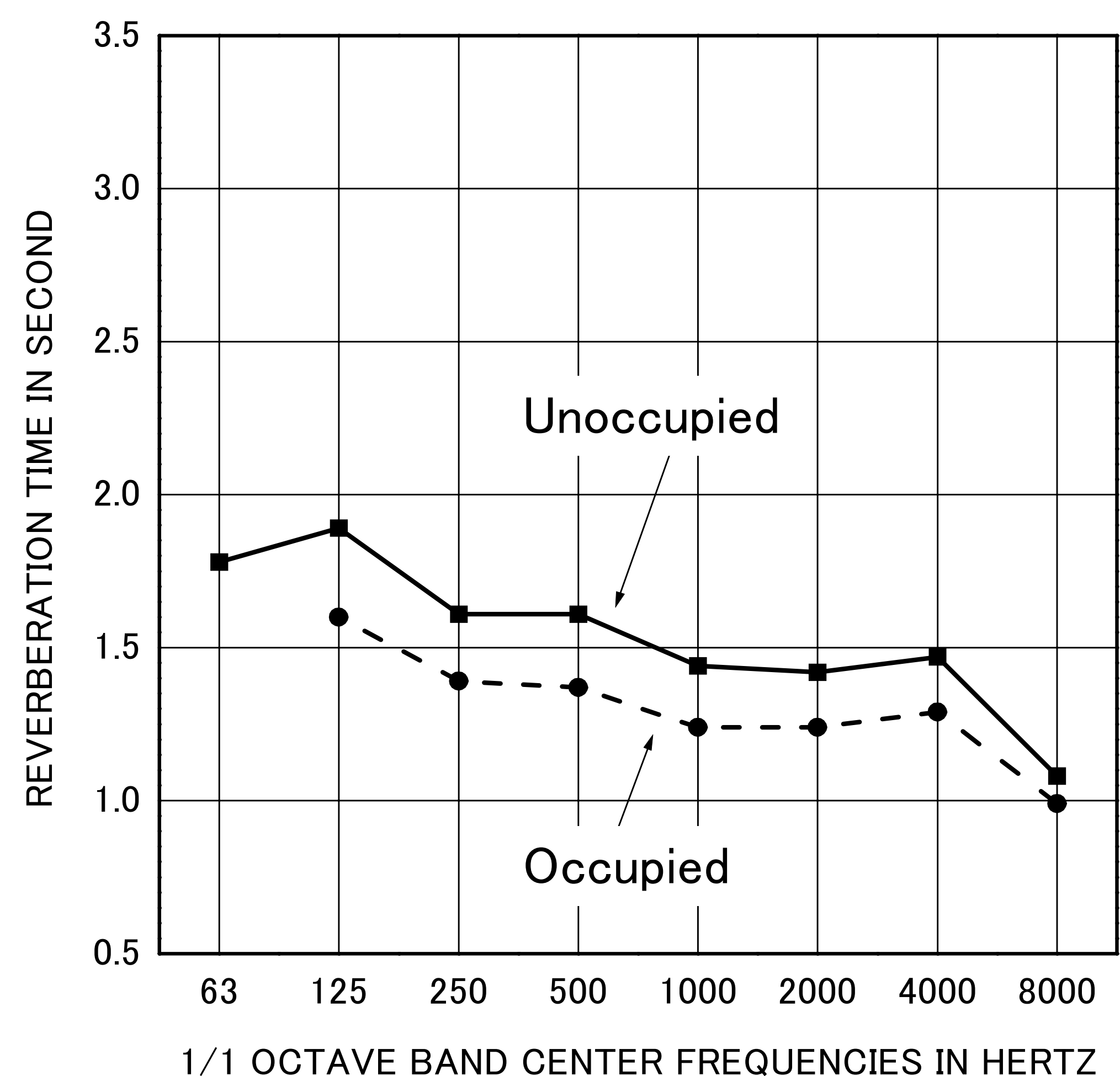

REVERBERATION TIME
(Variable Absorption Panel : close)

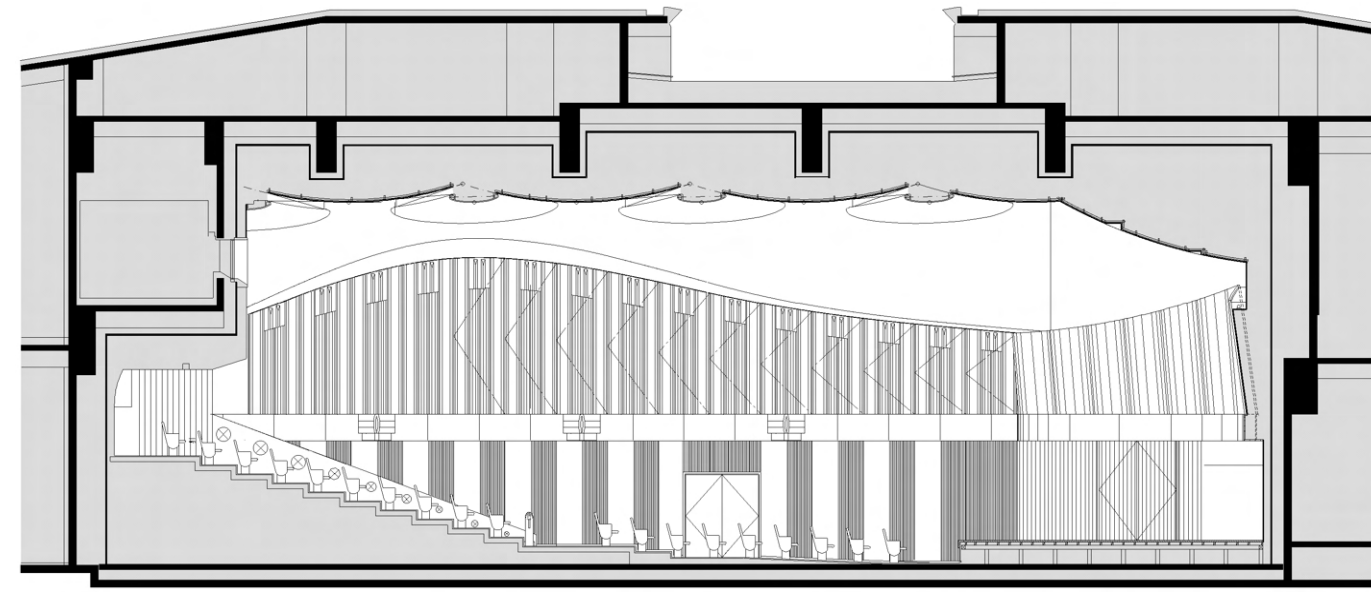

LONGITUDINAL SECTION

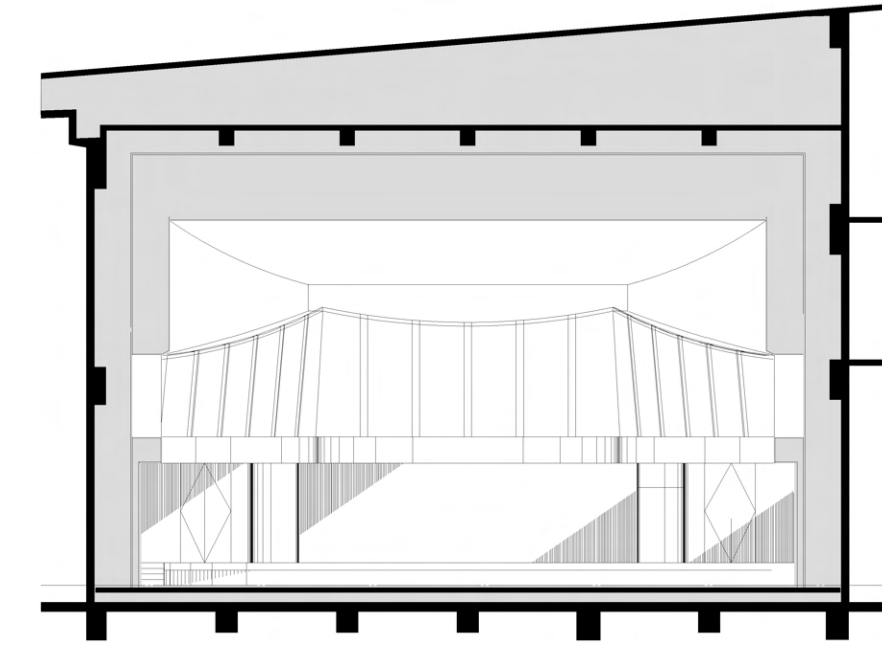

TRANSVERS SECTION

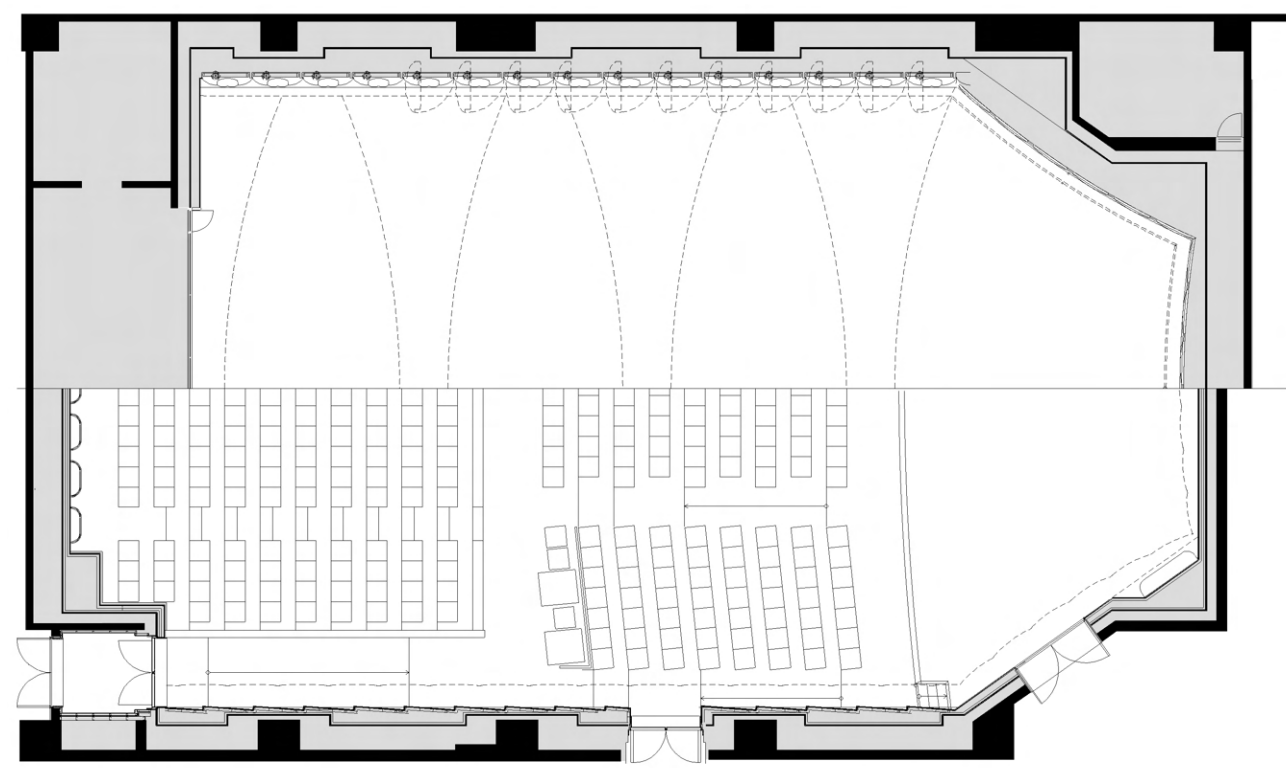

Upper, Ceiling

Lower

0 5 10 15 20 METERS

PLAN

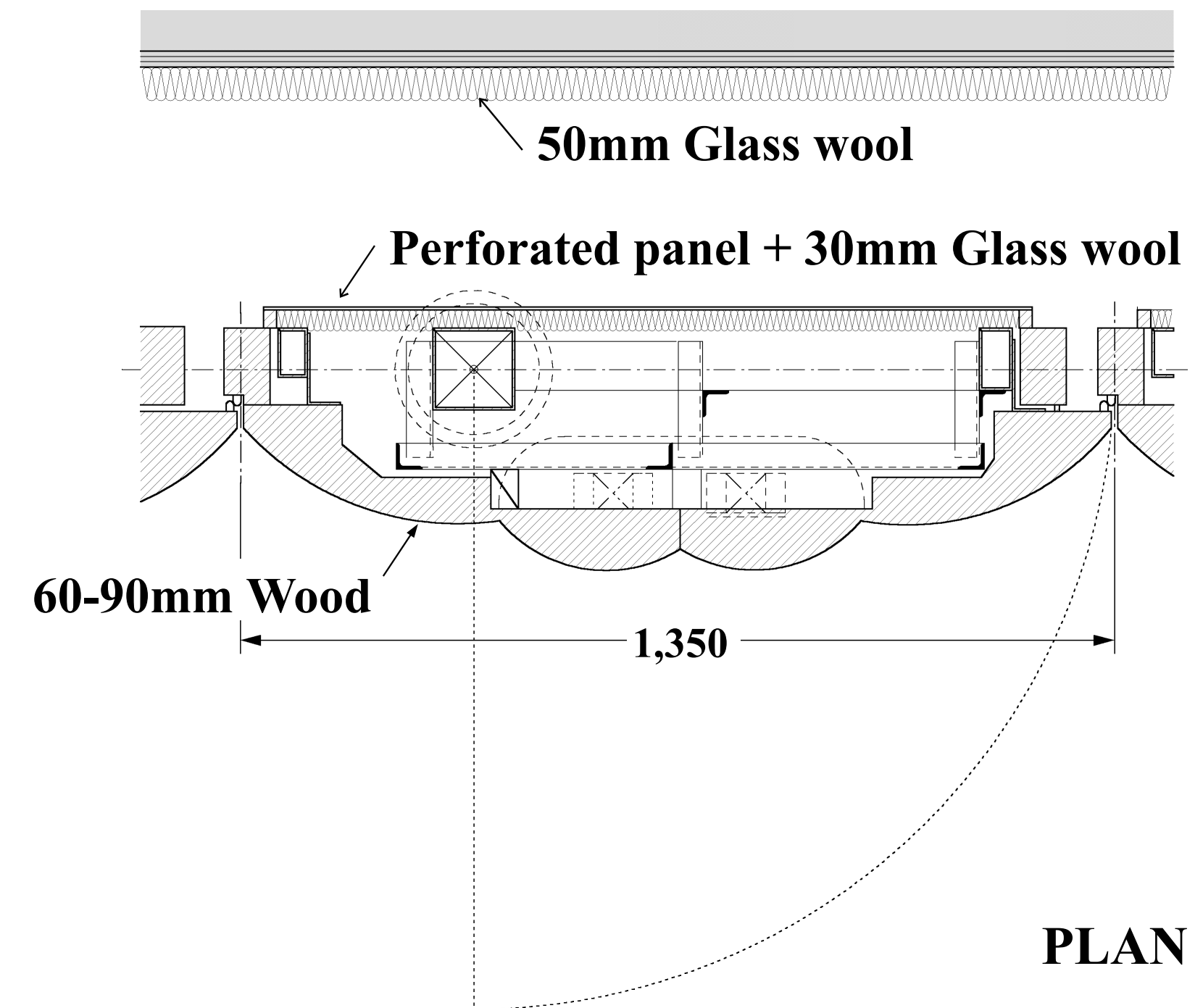

PLAN

VARIABLE ABSORPTION PANEL



VARIABLE ABSORPTION PANEL (OPEN)

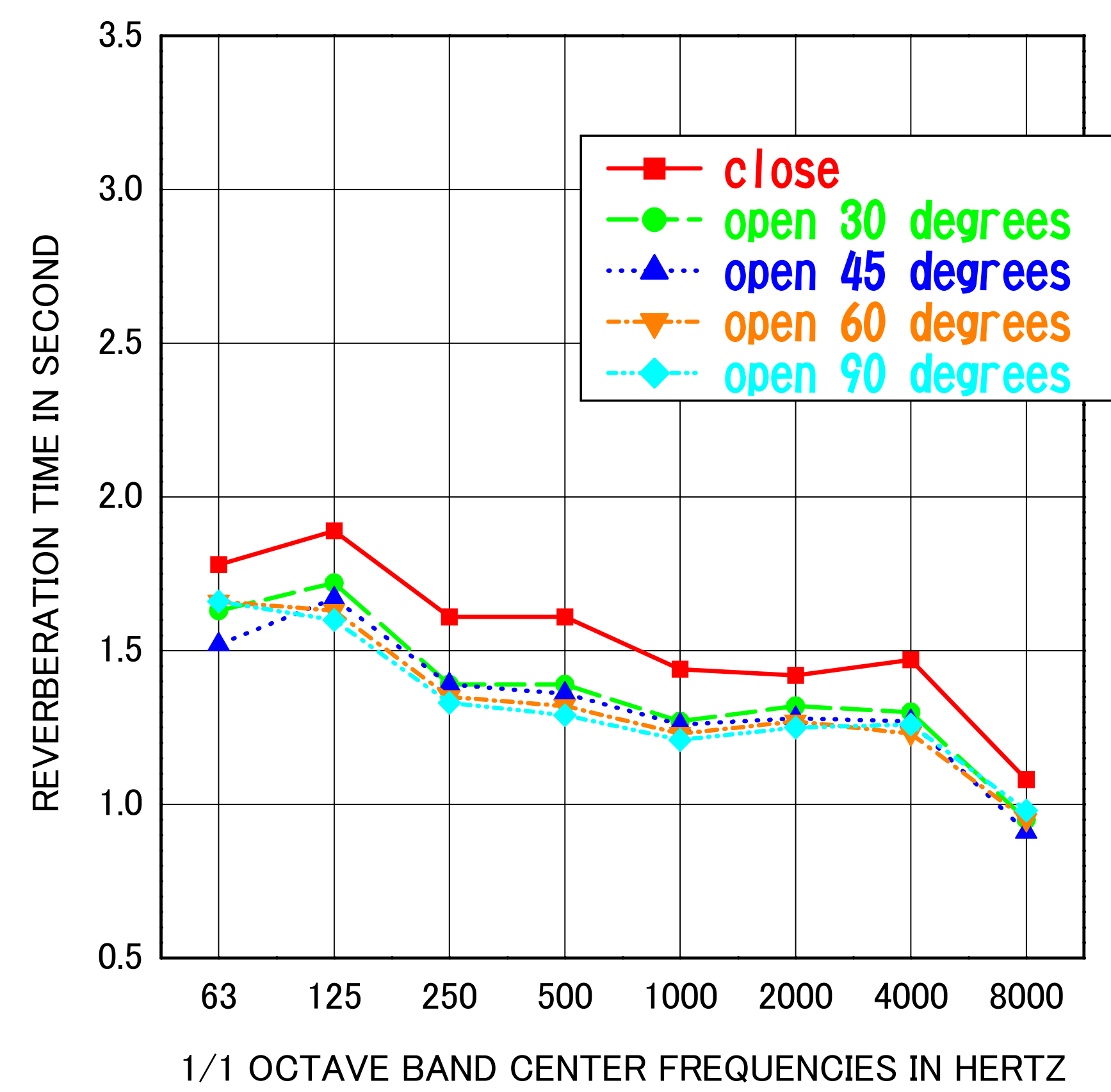

VARIATION OF REVERBERATION TIME